

HNF90I (Puma)

A versatile floodlight suitable for small to medium scale floodlighting for sports or similar areas. It offers good colour rendering with HPI-T metal halide lamps, or economical operation with SON-T high pressure sodium lamps. Robust and simple construction designed for easy aiming, quick maintenance and long service life.



Features and Benefits

- Robust and simple construction designed for easy aiming, quick maintenance and long service life.
- Suitable for multiple applications including industrial areas and sports facilities.

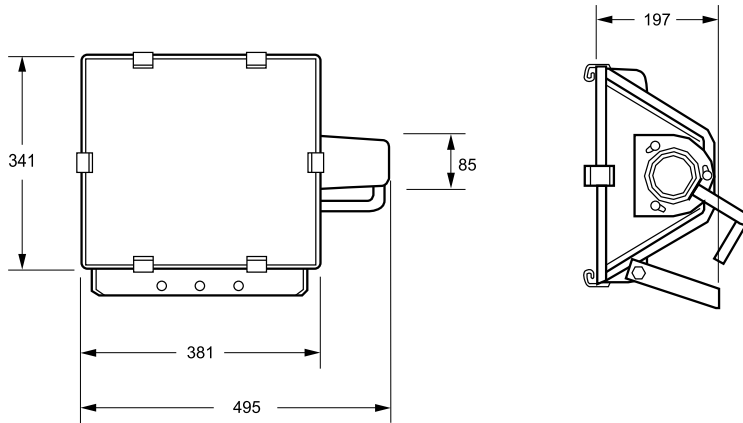

Product ID	L (mm)	W (mm)	H (mm)
HNF90I	495	197	341

Dimensions in mm (Nominal)

HNF90I (PUMA)			
Family Name	Puma	Control Gear	N/A
Model	HNF90I	Installation	Universal bracket
Wattage	N/A	IP rating	IP65
Lamp Colour	N/A	Weight	8kg
Colour Rendering Index (CRI)	N/A	Colour of housing	Silver
Flex and Plug	No	Application	Sports facilities / General areas / Industrial areas / Car Parks
Optics	NB, WB	Accessories	N/A

* Please note fitting is supplied without lamp

COMMERCIAL CODE	I2NC	DESCRIPTION
HNF90IGRNB	911401040780	HNF90I NARROW FLOOD
HNF90IGRWB	911401040380	HNF90I WIDE FLOOD
HNF90IBLNB	911401040880	HNF90I NRW FLD - BLACK